



CHAM

Pioneering CFD Software for Education & Industry

Natural Ventilation System in a Concept Home

PHOENICS Case Study - HVAC

Introduction

New regulations set by government agencies – no doubt coupled with the desire to minimize energy usage due to ecological social consciousness and cost reduction reasons - are leading an ever-increasing use of natural, rather than mechanical, ventilation and heating schemes.

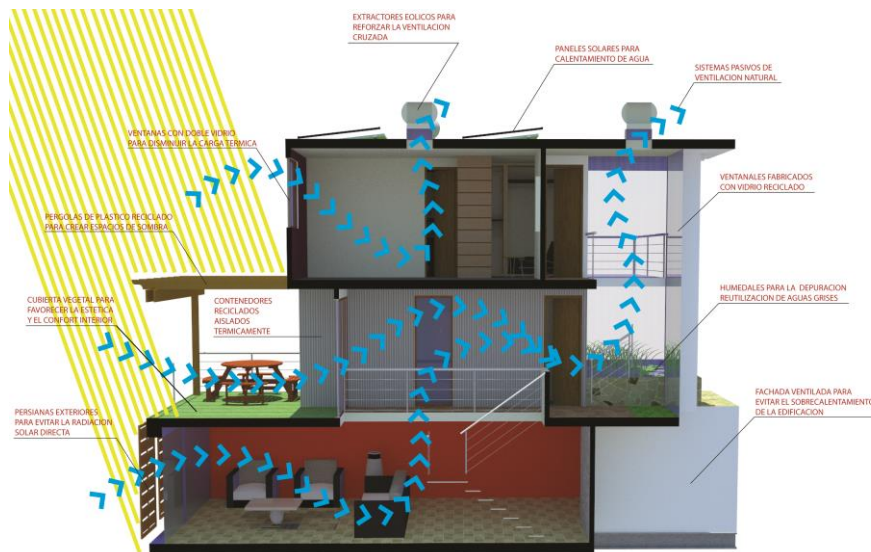

Figure 1. Design expectations

>>> indicates the expected air flow path through the structure.

In this demonstration example, PHOENICS/FLAIR was used to analyse the natural ventilation of a concept home, comparing it to initial expectations. The building in question was a private house, to which full recycling and bioclimatic concepts were applied. The building consists of re-cycled shipping containers and was designed by ASOLBA Ingeniería & Arquitectura, a firm of sustainable design and energy efficiency engineers located in Guayaquil, Ecuador and in Barcelona, Spain.

Setup

The initial conditions and model setup for the analysis were as follows:

Wind Speed	3m/s at 10m (using Log Law Wind Profile)
Mesh Size	~ 2 million cells
Num. of Iterations	4000

The wind profile also took into account the roughness height of the surrounding environment. In this example, it was set to 0.1m that represents low crops and occasional large obstacles. The house itself is a simplified version of the real model and excludes elements such as furniture and the stairwell. The louvers on the lower floor were represented as partial blockages. No account of solar gain was needed for this ventilation-only model.

Results

Figures 2 and 3 show two different cross-sectional views of the flow through the house. In the scenario considered, the majority of the air flow enters past the louver doors on the lower floor, proceeding upwards through the house and exiting through both the windows and the roof vents.

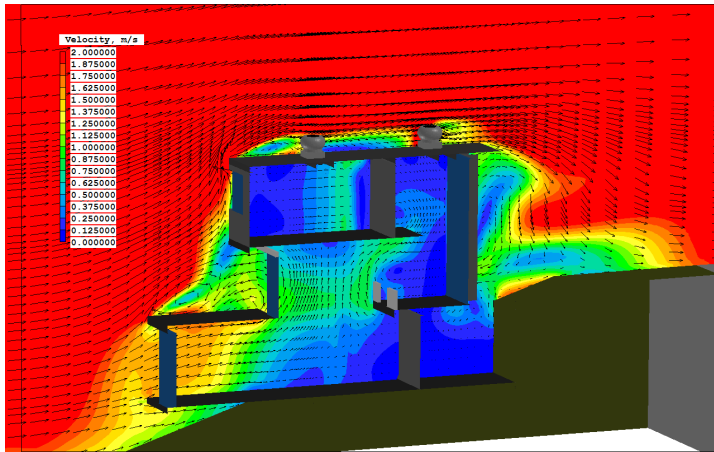

Figure 2. Velocity profile in x-plane

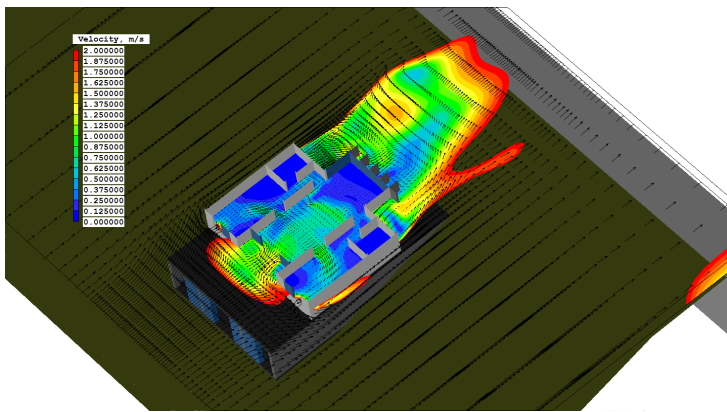

Figure 3. Velocity profile in z-plane

A streamline representation (Figure 4) confirms these findings that are in slight contradiction to the initial expectation of a more-even distribution of air entering through the windows on the middle and upper levels (Figure 1).

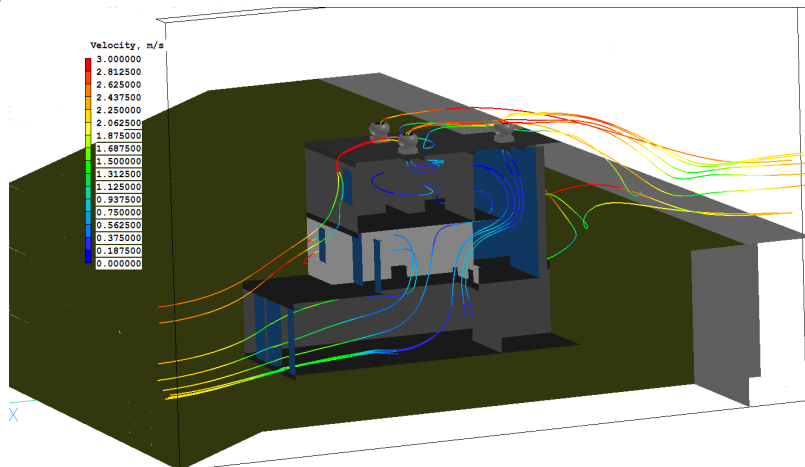

Figure 4. Streamline airflow in x-plane

As a next stage, the CFD model can be used inexpensively and quickly to ascertain whether more-restricted openings through the lower region would balance flow on each floor as required, or if other remedial action might be required.

Conclusion

Using CFD techniques in this manner greatly adds to the design capabilities of engineers and architects to improve and demonstrate the efficiency of particular housing designs. PHOENICS/FLAIR can be used to predict the comfort levels needed for the people inside them, through further analysis of, for example, solar radiation, humidity, internal heat sources and varying environmental conditions.