



**CHAM**

*Pioneering CFD Software for Education & Industry*

## Natural Gas Flame Simulation

### CHAM Case Study – Fire

#### Introduction

The following demonstration shows the calculation of natural gas combustion in the ambient air as an oxidant was carried out to show the dispersion conditions and the possible influence on the environment. The primary objective of the simulation is to predict the pollutant dispersion and the air conditions prevailing around the immediate vicinity of the combustion area.

#### Problem Specification

The case is based on CH<sub>4</sub> combustion at atmospheric pressure. The combustion process takes place in the area surrounded by firewalls to contain the heat emission from the flame. A 10 m/s wind is blowing from behind the building. The case geometry is presented in figures 1 and 2 below.

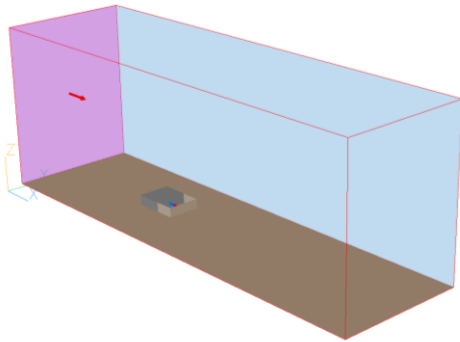

*Figure 1: Case geometry – whole view*

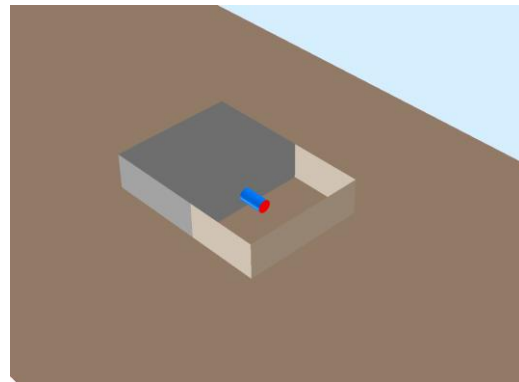

*Figure 2: Case geometry – combustion facility*

#### Computational Settings

The combustion of the gas was simulated using a three gas mixing model and standard k-e turbulence model. The “IMMERSOL” model was used to simulate thermal radiation from combustion gases. The computational grid used for the simulation consists of 65,000 structured cells. The model settings are as follows:

##### BOUNDARY CONDITIONS

- Wind inlet – fixed velocity boundary conditions -10 m/s
- Side and top outlets from the domain: fixed pressure boundary condition with atmospheric pressure
- Methane inlet – fixed velocity boundary condition.
- Ground plane – plate object

##### FUEL AND OXIDANT PROPERTIES

- Stoichiometric ratio – 17.4
- Heat of combustion – 50.0 MJ/kg
- Fuel Specific heat – 2.2 kJ/kgK
- Fuel molecular weight – 16.0
- Oxidant molecular weight – 29.0

##### COMPUTATIONAL GRID

- NX – 70 cells
- NY – 30 cells
- NZ – 31 cells



## Results of Computations

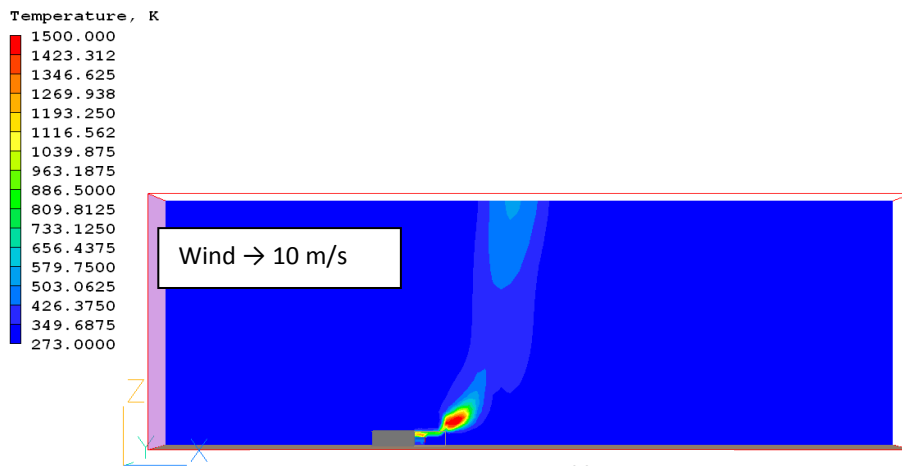

Figure 3: Temperature Field, K

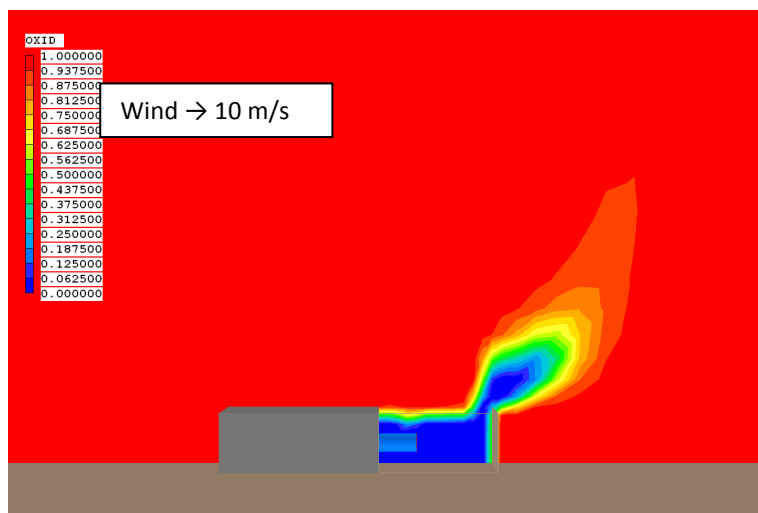

Figure 4: Oxidant concentration

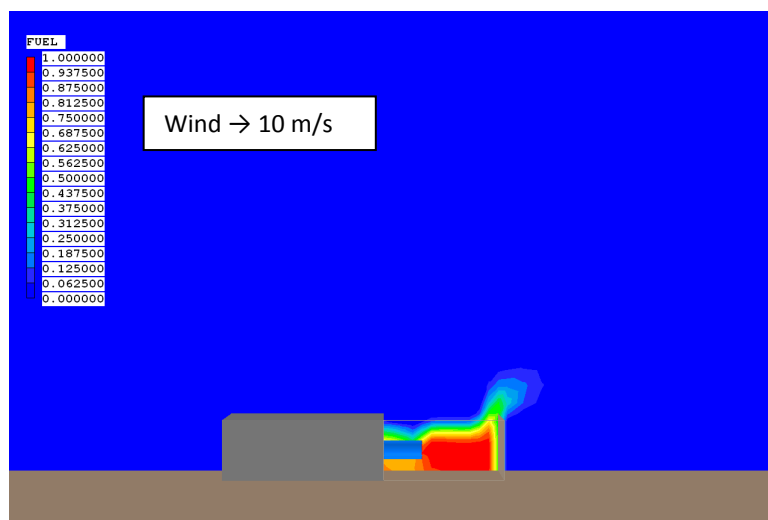
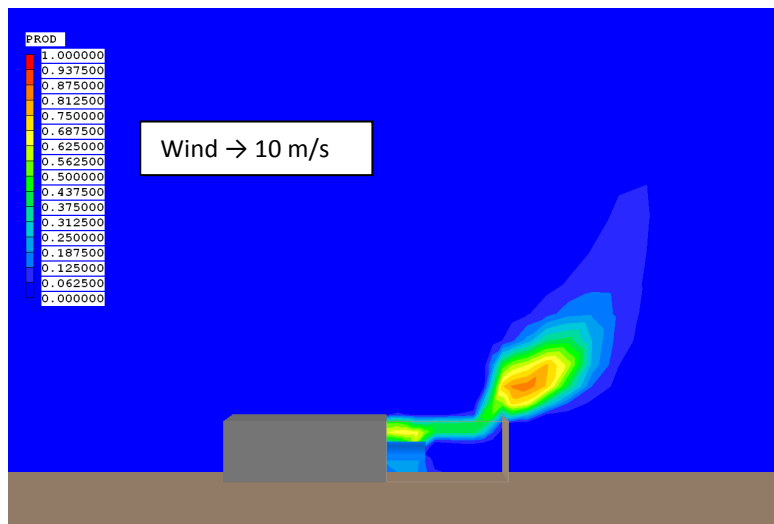

Figure 5: Unburned fuel concentration



**Figure 6: Combustion products concentration**

## Conclusion

The case demonstrates the capability of PHOENICS to model the combustion process in a simple and reliable way. The implementation of the combustion model allows the user to simulate the combustion of any fuel and predict the heat transfer and pollutant dispersion. Thermal radiation has been simulated in conjunction with combustion calculations using the inbuilt IMMERSOL model.

The case presented simulates methane combustion in ambient conditions. The simulation reveals that most of the flue gas is dispersed vertically due to natural convection driven by the density difference of the flue gas and the ambient air. The relatively high wind speed (10m/s) has a significant impact on the spreading of the combustion products across the region investigated.

The concentration of combustion products is high in the immediate local of the combustion area, and is contained by the firewall. Whilst the firewall restricts the dilution of the flue gas by the passing air, it does perform its primary function of reducing the heat impact upon the surrounding environment.